

# Down/Up Converter

## L1 GPS Antenna Down/Up Converter

### KEY FEATURES

- Increases Antenna Cable Length Up to 1500 ft. (457 meters)
- Excellent Signal Noise Immunity
- Signal Conversion Transparent to the GPS Receiver
- Eliminates Need for Cable Amplifiers

GPS signal down/up conversion is required when signal losses in the antenna cable limit the distance between the receiver and the antenna assembly. At just over 250 feet (76 meters) in cable length, the benefits can be realized using a Down/Up Converter assembly versus the use of low loss cable and amplifiers. Signal strengths and noise immunity as well as the cost benefits over the use of low loss cable and amplifiers are the main advantages of using the Antenna Down/Up Converter assembly.

The down converter antenna and up converter unit replace the standard L1 GPS antenna. Power for the system is provided by the GPS receiver or an optional external power supply. The down/up conversion process is transparent to the GPS receiver. As with any precision timing GPS receiver, only cable delay and down conversion delays need to be entered into the receiver.

The Down/Up Converter may also work with non-Symmetricom L1 GPS receivers. The signal output from the converter is L1 C/A code that can be decoded by any L1 GPS receiver. Since the Down/Up Converter can be externally powered, L1 GPS receivers that can interface to the Down/Up Converter BNC connector should be able to use the signal. However, note that the Down/Up Converter introduces latency in the signal in addition to cable delay. For precision timing applications the receiver must be able to account for these factors.



Down/UP Converter

## Down/Up Converter Specifications

### ANTENNA DOWN CONVERTER

- Physical specifications

Size: 4.4" W x 2.1" H (11.17 cm W x 6.85 cm H)  
 Weight: (including mounting mast): 0.60 lb. (0.272 kg)  
 Cable: RG-58  
 Available lengths = 250 - 1500' (76-457 m),  
 50' (15 m) standard, 2.7 lb. (1.23 kg) per 100' (30 m)  
 Recommended: Belden 8219 or Belden  
 Plenum 88240

- Operating specifications

Power: +12 Vdc @ 135 mA  $\pm$ 10%  
 LO frequency: 16.368MHz @ 1 Vp-p  
 IF frequency: 4.092 MHz @ 1 Vp-p  
 Antenna frequency (L1): 1575.42 MHz  
 Input code: L1 C/A Code  
 I/O connector: Female TNC

- Environmental specifications

Operating temperature: -40°C to + 70°C  
 Storage temperature: -55°C to + 85°C  
 Humidity: 100%, condensing

### ANTENNA UP CONVERTER

- Physical specifications

Size: 6.8" L x 4.2" W x 1.8" H  
 (17.27 cm L x 10.67 cm W x 4.57 cm H)  
 Weight: 1.5 lb. (0.68 kg)  
 Cable: RG-59  
 3 ft. (91 cm)  
 Recommended: Belden 9104 or Belden  
 Plenum 9104P

- Operating specifications

Power: +12 Vdc @ 200 mA  $\pm$ 10% including Down Converter  
 Input LO frequency: 16.368MHz @ 1 Vp-p received from the  
 Down Converter  
 Input IF frequency: 4.092 MHz @ 1 Vp-p received from the  
 Down Converter  
 Output frequency (L1): 1575.42 MHz  
 Output Code: L1 C/A Code

- Environmental specifications

Operating temperature: 0° C to + 50° C  
 Storage temperature: -40° C to + 85° C  
 Humidity: 95%, noncondensing

- Up converter connection

To antenna: Female BNC  
 To receiver: Female TNC

### CERTIFICATIONS

- FCC, CE, UL

### PRODUCT INCLUDES

- L1 GPS antenna down converter
- Up converter
- 1 ft. Mounting mast (30 cm)
- 2 Clamps
- 3 ft. Up converter cable (91 cm)
- 50 ft. Antenna cable (15 m)\*
- Manual

### OPTIONS

- External 12Vdc power supply for computer plug-in card applications  
 Input: 100-240 Vac, 47-63 Hz  
 DC output: +12 Vdc/2.1 A
  - Lightning arrester
  - Antenna cables: 250, 500, 750, 1000, 1250 and 1500 feet,  
 (76, 152, 228, 305, 381 and 457 meters)
- \*Optional extended cable lengths are provided in lieu of 50ft. cable

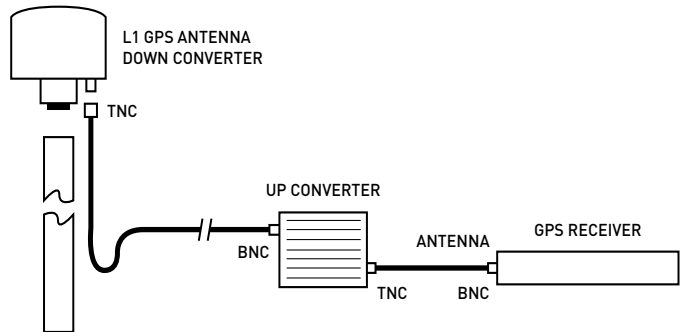

Down/Up Converter Configuration



**SYMMETRICOM, INC.**  
 2300 Orchard Parkway  
 San Jose, California  
 95131-1017  
 tel: 408.433.0910  
 fax: 408.428.7896  
 info@symmetricom.com  
 www.symmetricom.com